

SY 50 LF

Material

Cast iron

Dimensions

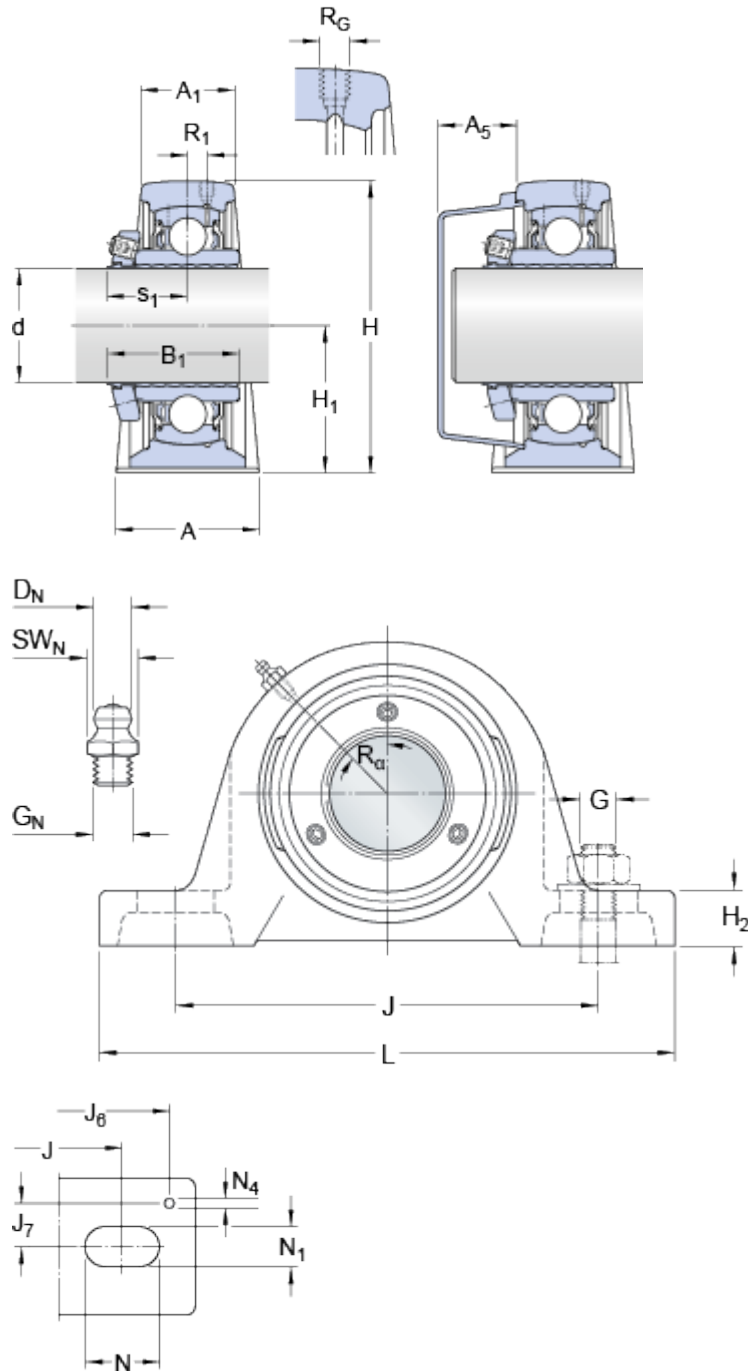

d	50	mm	
d	51.66	mm	
A	54	mm	
A ₁	34	mm	
A ₅	29.5	mm	
B ₁	46	mm	
H	114	mm	
H ₁	57.2	mm	
H ₂	22	mm	
J	157	mm	
J	max.	165	mm
J	min.	149	mm
L	203	mm	
N	26	mm	
N ₁	18	mm	
s ₁	27.5	mm	

Dowel pins

J ₆	187	mm
J ₇	19	mm
N ₄	4	mm

Grease fitting

D _N	6.5	mm
SW _N	7	mm
G _N	1/4-28 SAE-LT	

Threaded hole

R_G	1/4-28 UNF	
R_1	4	mm
R_a	45	°

Values for B_1 and s_1 before the grub screw is tightened (sleeve and inner ring bore at starting position).

Calculation data

Basic dynamic load rating	C	35.1	kN
Basic static load rating	C_0	23.2	kN
Fatigue load limit	P_u	0.98	kN
Limiting speed		4000	r/min

Mass

Mass of unit		2.65	kg
--------------	--	------	----

Mounting information

Hexagonal key size for grub screw	N	3	mm
Recommended tightening torque for grub screw		7.4	N·m
Appropriate SKF mounting kit		626830	
Recommended diameter for attachment bolts, mm	G	16	mm
Recommended diameter for attachment bolts, inch	G	0.625	in

Appertaining products

Housing	SY 510 M
Bearing	YSP 210 SB-2F

Appropriate products

End cover	ECY 210
-----------	---------